

Building Simulation in the United States

eSim 2001 – June 14, 2001

Charles S. Barnaby
Wrightsoft Corporation

The 30 Minute Tour

- Research methods
 - Talking to people
 - Web searching
 - Broadcast E-mail
 - Unpublished reports
- High points at best

Themes

- Hand-wringing re low use in design
- Usability
 - Interfaces
 - Packaging
- Accuracy and/or sensitivity
- Flexibility
- Interoperability
- EnergyPlus

Not in Design Mainstream

- Simulation is used in the design process of perhaps 5% of U.S. buildings
- Why: short-range economic time horizon
- Usability not limiting issue
 - Computerized load calcs are routine
 - Many specialized design applications are used – CAD, lighting

But Many Niches ...

- Code compliance
- Rating
- Policy development
- Energy services
- Design assistance
- Research
- Education

U.S. Tool Characteristics

U.S. buildings typically cooled: tools emphasize –

- Mechanical system performance
- Air-based HVAC systems
- Controls

Weaker coverage

- Envelope
- Natural ventilation
- Space temperature

EnergyPlus addresses weaknesses

Widely-Used Tools

- DOE-2
 - LBNL: DOE 2.1E
 - J.J. Hirsch: DOE 2.1E, DOE 2.2, PowerDOE, eQUEST
- Energy-10: NREL
- Manufacturers
 - HAP: Carrier
 - Trace: Trane
- TRNSYS: University of Wisconsin, TESS
- BLAST: University of Illinois

Future Tools?

Web-based

- EDR Charette
- MIT Design Advisor

Equation-based

- SPARK: LBNL
- TRNSYS / EES: F-Chart Software

Sizing

- Trane Trace, Carrier HAP
- Wrightsoft Right-Suite Commercial
- Elite CHVAC

Interfaces

DOE-2

- VisualDOE – GUI front end
- EnergyGuage – Residential
- EnergyPro – California compliance

TRNSYS

- IISiBat – graphic (drag and drop) system schematic editor

Packaging

DOE-2: Interface developers provide complete solutions

TRNSYS: Coherent libraries assembled by Thermal Energy System Specialists (TESS)

EnergyPlus

- All new general building simulation code, “best of” BLAST and DOE-2
- Five year DOE development effort
- Version 1.0 released April 2001
- Engine only (batch text interface)
- Wide distribution
- How fast will it come into use? 1-2 yrs?

EnergyPlus Structure

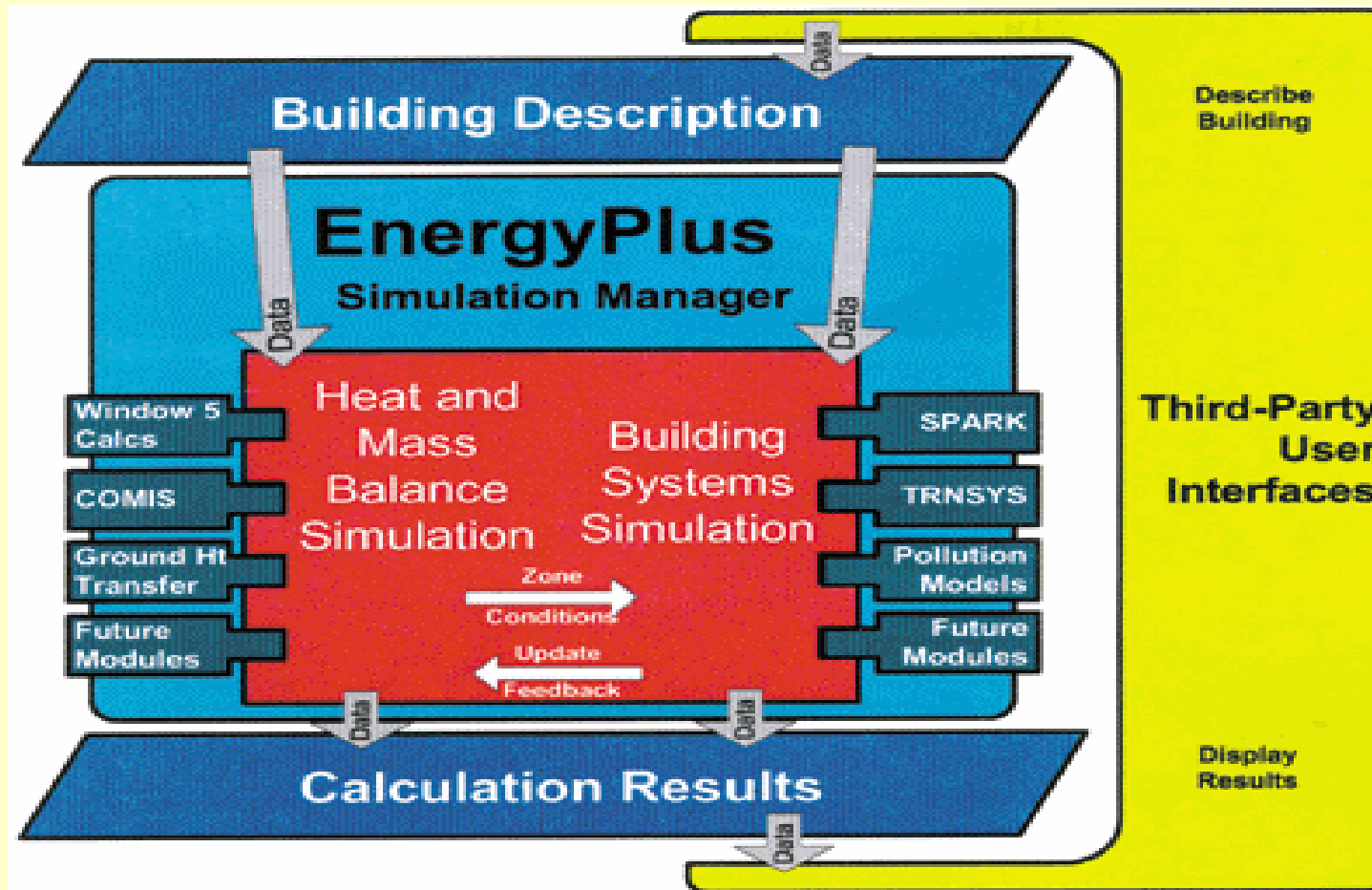

EnergyPlus Systems

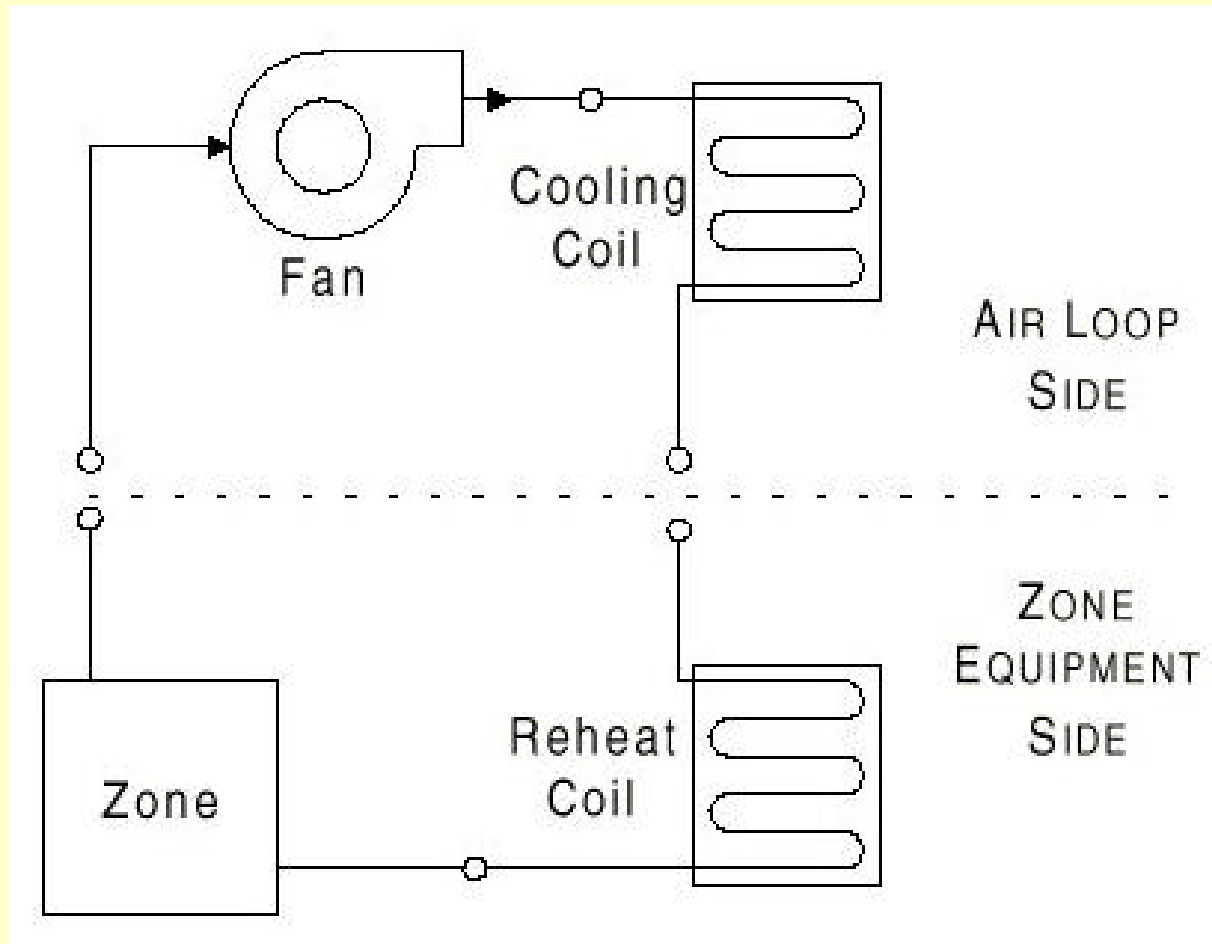

Code Compliance

- Many energy codes have provision for simulation, used only if advantageous
- California
 - Residential: 20,000+ simulation studies per year
 - Non-residential: less simulation
- Florida
- Pacific Northwest
- Model Energy Code -- ComCheck
- ASHRAE Standard 90

Ratings

Leadership in Energy & Environmental Design (LEED)

- U.S. Green Building Council
- Points for energy performance in excess of ASHRAE Standard 90.1
- Owners beginning to require LEED rating as performance minimum

HERS – Home Energy Rating System

Policy Development

California Title 24

- CALPAS, CALRES, DOE-2

Non-Residential New Construction (NRNC) database

- 1000+ audited building sample of all CA non-res buildings
- Generate and run parametric DOE-2 simulations
- Weighted results = accurate whole-state estimates

Utility programs

Energy Services

Calibrated simulation

- Evaluate proposed retrofits
- Determine savings as part of measurement and verification (M&V) (but simple statistics better?)
- Estimate load shapes from monthly bills

Design Assistance

Savings By Design

- Up to \$50,000 design team incentives, based on exceeding Title 24
- Design advice
- Joint program of CA investor utilities

Other utilities

Research

- ASHRAE TC 4.7 – Toolkits etc.
- Model development
- Policy studies
- Active groups at national labs and many universities

Education

- Architecture (Energy-10)
- Mechanical engineering (DOE-2, TRNSYS)
- Professional training (DOE-2, PowerDOE, ...)
- Many universities, per faculty interest

Interoperability

International Alliance for Interoperability (IAI)

- 600 organization consortium
- CAD vendors
- Industry Foundation Classes (IFC)

Ad hoc

Validation

BESTEST: IEA testing method

ASHRAE

- RP-1062: Envelope test cases
- RP-865: HVAC test cases
- SPC 140: Standard language version of BESTEST

Links

Directories

- www.eren.doe.gov/buildings/tools_directory
- www.energyideas.org

E-mail list

- BLDG-SIM@gard.com

DOE-2, SPARK, EnergyPlus

- simulationresearch.lbl.gov

DOE 2.2, PowerDOE, eQUEST

- www.doe2.com
- www.energydesignresources.com

Links

Energy-10

- www.sbicouncil.org/enTen/index.html

TRNSYS / IISiBat / EES

- www.tess-inc.com
- sel.me.wisc.edu
- www.fchart.com

Manufacturer software

- HAP 3.2: www.carrier-commercial.com
- Trace 700: www.trane.com/commercial/software

Links

Interfaces

- VisualDOE: www.eley.com
- EnergyGuage: www.fsec.ucf.edu
- EnergyPro: www.energysoft.com

Design assistance

- www.savingsbydesign.com

Non-Residential New Construction database

- www.calmac.org

Links

Interoperability

- iajweb.lbl.gov

Web-based tools

- EDR Charette: www.energydesignresources.com
- MIT Design Advisor:
<http://18.80.2.250:8080/design>

Model Energy Code

- www.eren.doe.gov/buildings/codes_standards/buildings

Links

LEED Rating

- www.usgbc.org/programs/leed.htm

BESTEST

- diane_littau@nrel.gov